

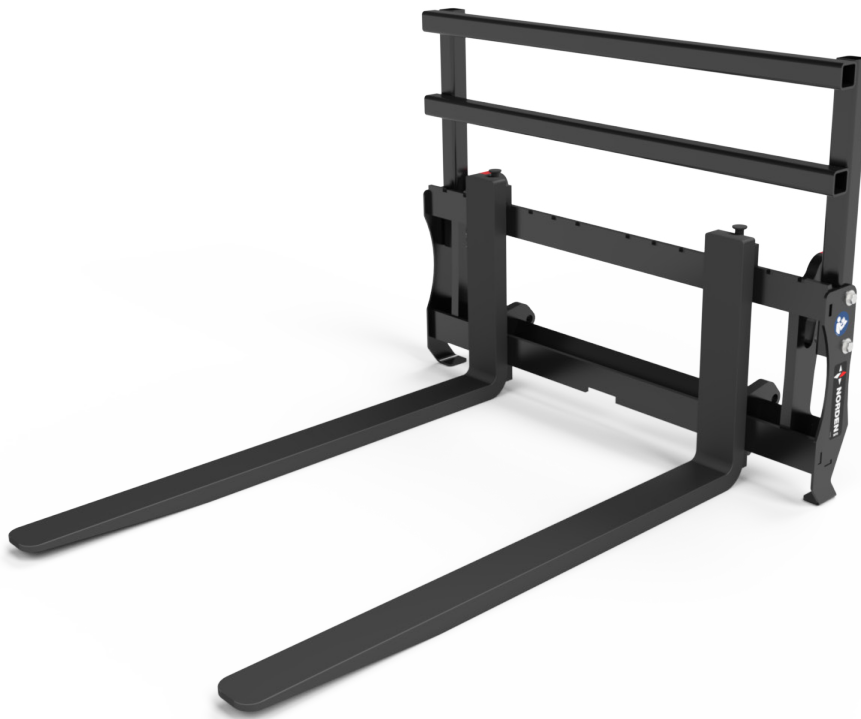

**NORDEN** MFG

# Owner Manual

Euro Pallet Forks



EPF 5500

**MADE IN THE USA** 

Read, Understand, and Follow this manual which provides information and procedures to safely operate and maintain the attachment.





## CONTENTS

<b>1. INTRODUCTION</b>	<b>4</b>
1.1 Intended Usage	4
1.2 Operator Orientation	4
1.3 Specifications	4
1.3.1 EPF 5000 Specifications	4
1.4 Serial Number Location	4
1.5 Product Improvements	5
1.6 Disposal of Equipment at End of Useful Life	5
1.7 Unanswered Questions	5
<b>2. SAFETY</b>	<b>6</b>
2.1 General	6
2.2 Safety Alert Symbol	6
2.3 Safety Icons Nomenclature	7
2.3.1 Personal Protection / Important Information	7
2.3.2 Prohibited Actions	7
2.3.3 Hazard Avoidance	7
2.4 General Safety	8
2.5 Machine Related Safety	8
2.6 Safety Decals	8
2.7 Operation Safety	8
2.8 Transporting Safety	8
2.9 Storage Safety	8
2.10 Maintenance Safety	8
2.11 Training	8
2.12 Authorization / Training Sign-Off Form	9
<b>3. SAFETY DECALS AND LABELS</b>	<b>11</b>
3.1 General Information	11
3.2 Contact Information	11
3.3 How to Install Replacement Safety Decals	11
3.4 Safety Sign Locations	12
3.5 Safety Decals	12
<b>4. NOMENCLATURE</b>	<b>13</b>
<b>5. ASSEMBLY AND SETUP</b>	<b>14</b>
5.1 Installing Fork Arms On Pallet Fork Frame	14
<b>6. USAGE</b>	<b>15</b>
6.1 User Safety	15
6.1.1 Machine Operation Recommendations	15
6.1.2 Machine Requirements	15
6.2 Machine Specifications	16
6.3 Attaching to Machine	16
6.4 Pre-Operation Checklist	17
6.5 Usage	17
6.5.1 Picking Up a Pallet	18
6.5.2 Moving the Pallet	18
6.5.3 Placing the Pallet	19
6.6 Detaching from Machine	19
<b>7. TRANSPORTING</b>	<b>20</b>
7.1 Highway and Transport Safety	20
7.2 Pre-transport Checklist	20
<b>8. STORAGE</b>	<b>21</b>
8.1 Placing in Storage	21
8.2 Removing from Storage	21

<b>9. MAINTENANCE</b>	<b>22</b>
9.1 Maintenance Safety	22
9.2 Practice Safe Service Procedures	22
9.3 Bolt Torque Requirements	23
9.4 Welding Repairs	23
9.5 Service Record	24
<b>10. PARTS SECTION</b>	<b>25</b>
10.1 Ordering Parts	25
10.2 Contact Information	25
10.3 Safety Decals and Instructional Labels	25
10.4 EPF 5500 Parts Detail	26

# 1. Introduction



The Norden Euro Pallet Fork is an attachment that mounts to a utility tractor equipped with a loader having Euro style mounting capabilities. **It is designed specifically to move pallets.**

**Note:** The specific term “pallet fork attachment” will be referred to simply as “pallet fork” or “attachment” throughout the rest of this manual and may refer to any of the models covered by this manual. The term of “utility tractor” will be referred to as “machine” throughout this manual.

Read, understand, and follow the manual carefully to become familiar with your new Norden Pallet Fork. Ultimately it is our desire that you will be operating your pallet fork as a seasoned professional in very little time!

## 1.1 Intended Usage

Do not use this pallet fork for any other purpose than its intended use of moving pallets.

**Note:** Do not use an oversized machine; the pallet forks are intended to be used on machines rated up to 120 HP or a 3500 pound operating capacity.

## 1.2 Operator Orientation

The directions left, right, front, and rear, as mentioned throughout this manual, are as seen from the operator’s seat, facing in the direction of travel.

## 1.3 Specifications

Specifications subject to change without notice.

### 1.3.1 EPF 5000 Specifications



<b>Overall Width</b>	48.5"
<b>Overall Length</b>	55.2"
<b>Overall Height</b>	36"
<b>Overall Approximate Weight</b>	428 lb.
<b>Nominal Blade Dimensions</b>	4.00" x 1.58" x 48.00"
<b>Pallet fork Rating (Pair)</b> Front of shank to load point is 19.68" (500mm)	5,500 lbs.

## 1.4 Serial Number Location

The pallet fork’s serial number and model number are on the data plate which is located on the front of the pallet fork frame. Please use these numbers when requesting service, seeking information, or ordering parts.

1.

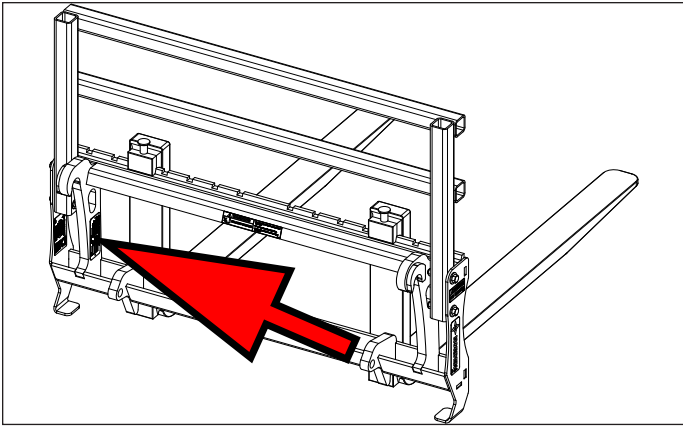

Record the serial and model numbers as well as the date of purchase in the space provided for easy reference when contacting Norden Mfg LLC with questions.

Model Number \_\_\_\_\_

Serial Number \_\_\_\_\_

Date of Purchase \_\_\_\_\_

### 1.5 Product Improvements

Because Norden Mfg LLC maintains an ongoing program of product improvement, we reserve the right to make improvements in design or changes in specifications without incurring any obligation to install them on attachments previously sold.

### 1.6 Disposal of Equipment at End of Useful Life

The Norden Mfg LLC pallet forks are designed for the specific purpose of moving pallets. When this pallet fork is no longer capable of performing its intended use, it should be dismantled and scrapped. Do not use any materials or components from this pallet fork for any other purpose.

### 1.7 Unanswered Questions

If you have any questions not answered in this manual, require additional copies, or the manual is damaged, please contact your dealer or:

Norden Mfg LLC  
4210 Kinsman Road NW  
North Bloomfield, OH 44450

Phone: (877) 296-5851  
Fax: (440) 693-4336  
E-mail: [parts@nordenmfg.com](mailto:parts@nordenmfg.com)

The manual is also available for download at:  
[www.nordenmfg.com](http://www.nordenmfg.com)

## 2. Safety

### 2.1 General

Most work-related accidents are caused by failure to observe basic safety rules or precautions. An accident can often be avoided by recognizing potentially hazardous situations before an accident occurs. As you use and maintain the pallet fork you must be alert to potential hazards.

Improper use and/or maintenance of this pallet fork could cause a dangerous situation that results in property damage, personal injury, or death.

#### **WARNING**



**Do not use the pallet fork until you read, understand, and follow the information contained in this manual and all related equipment manuals. Do not use the pallet fork for anything other than its intended purpose.**



**Safety precautions and warnings are provided in this manual and on the pallet fork. If these precautions and warnings are not followed, bodily injury or death could occur to you or to other persons.**

Norden Mfg LLC cannot anticipate every possible circumstance that might involve a potential hazard. The warnings in this manual and on the product are, therefore, not all-inclusive. If a method of operation not specifically recommended by us is used, you must satisfy yourself that it is safe for you and for others. You should also ensure that the attachment will not be damaged or be made unsafe by the use or maintenance methods that you choose.

The information, specifications, and illustrations in this manual are based on the information that was available at the time this material was written and can change at any time.

### 2.2 Safety Alert Symbol



This is the safety alert symbol. It is used to alert you to potential personal injury hazards. The symbol is followed by a signal word such as “WARNING” or “CAUTION” depending on the severity of the potential hazard. Obey all safety messages that follow this symbol to avoid possible injury or death.

This manual contains WARNINGS, CAUTIONS, NOTICES, SAFETY INSTRUCTIONS, and NOTES. Warnings, Cautions, and Safety Instructions must be followed to prevent the possibility of personal injury or death due to improper operation. Notices and Notes help prevent pallet fork or property damage.

#### **WARNING**

Indicates a potentially hazardous situation which, if not avoided, **COULD** result in death or serious injury.

#### **CAUTION**

Indicates a potentially hazardous situation which, if not avoided, **MAY** result in minor or moderate injury.

#### **NOTICE**

Indicates that pallet fork or property damage can result if instructions are not followed.

#### **SAFETY INSTRUCTIONS**

**Indicates specific safety-related instructions or procedures.**

**Note:** Contains additional information important to operation or a procedure.



## 2.3 Safety Icons Nomenclature

This manual and the pallet fork has numerous safety icons. These safety icons provide important operating instructions which alert you to potential personal injury hazards

### 2.3.1 Personal Protection / Important Information

-   *Read the manual*
-  *Maintenance procedure*
-  *Eye protection*
-  *Hearing protection*
-  *Hand protection*
-  *Foot protection*
-  *First aid kit*
-  *Use proper tools*
-  *Use OEM parts*
-  *Use ROPS and seat belt*
-  *Maintain safety decals*
-  *Place in park*
-  *Remove key*
-  *Stop engine*
-  *Visibility - slow moving vehicle (SMV)*
-  *Set parking brake*

### 2.3.2 Prohibited Actions

-  *Do not alter or modify*
-  *Do not leave out tools*

-  *Do not weld*
-  *No riders*
-  *No children*
-  *No alcohol*
-  *No drugs*

### 2.3.3 Hazard Avoidance

-  *Crushing hazard*
-  *Crushing hazard*
-  *Slipping hazard*
-  *Tripping hazard*
-  *Falling hazard*
-  *Safety alert symbol*
-  *Defective or broken part*
-  *Falling hazard*
-  *Maintain safe distance*
-   *Pinch point hazard*
-  *Crush hazard*
-  *Rollover hazard*
-  *Not a lifting device*
-  *Entanglement hazard*

## 2.4 General Safety

### **WARNING**



#### **Read, Understand, and Follow Manual**

To prevent personal injury or even death, be sure you read, understand, and follow all of the instructions in this manual and other related OEM equipment manuals! This attachment was designed for a specific application; **DO NOT** modify or use this attachment for any application other than that for which it was designed. Attachments used improperly or by untrained personnel can be dangerous! Inexperienced operators should receive instruction from someone familiar with the pallet fork and the machine before being allowed to use the pallet fork.



#### **Do Not Operate**

Do not use the attachment if it is in need of repair. If you believe the pallet fork has a defect which could cause injury or death, you should immediately stop using the pallet fork.



#### **Fall Hazard**

Do not use the attachment as a platform for standing. Do not stand on top of the attachment at any time. Do not hang on the attachment or allow others to hang on it.



#### **Pinch Point Hazard**

Keep hands and feet away from the attachment to prevent them from getting pinched or crushed.

## 2.5 Machine Related Safety



#### **Impaired User Hazard**

Do not attempt to use or maintain the attachment under the influence of drugs or alcohol. Consult your doctor before using the attachment while taking prescription medications.



#### **Falling Hazard**

Do not allow riders on the machine or attachment at any time. Falling can result in severe injuries or death.



#### **Not A Lifting Device**

Only lift palletized loads. Do not use the pallet fork to lift other objects.

### **WARNING**



#### **Stay Clear**

Clear the area of people, especially small children, before using the attachment. Under no circumstances should young children be allowed to work with or around the pallet fork.

## 2.6 Safety Decals

Refer to section “3. Safety Decals and Labels” on page 11 for safety recommendations related to using the attachment.

## 2.7 Operation Safety

Refer to section “6.1 User Safety” on page 15 for safety recommendations related to using the pallet fork. All applicable safety recommendations in other sections should also be followed.

## 2.8 Transporting Safety

Refer to “7. Transporting” on page 20 for safety recommendations related to traveling with a machine and attachment on a public roadway. All applicable safety recommendations in other sections should also be followed.

## 2.9 Storage Safety

Refer to section “8. Storage” on page 21 for safety recommendations related to storing the pallet fork. All applicable safety recommendations in other sections should also be followed.

## 2.10 Maintenance Safety

Refer to section “9. Maintenance” on page 22 for safety recommendations related to maintaining the pallet fork. All applicable safety recommendations in other sections should also be followed.

## 2.11 Training

Norden Mfg LLC follows the general Safety Standards specified by the Farm Equipment Manufacturers Association (F.E.M.A.), and the American National Standards Institute (ANSI). Anyone who will be using and/or maintaining the pallet fork must read and clearly understand ALL safety, operation, and maintenance information presented in this manual, other related OEM machine manuals, and the safety decals.



If you do not understand any information in this manual, see your dealer or contact Norden Mfg LLC before proceeding.

Do not use or allow anyone else to use this attachment until all information has been reviewed. Annually review this manual before the season start-up.

Make periodic reviews of SAFETY and OPERATION a standard practice. An untrained operator is not qualified to use this pallet fork.

## **2.12 Authorization / Training Sign-Off Form**

The authorization and training sign-off form is provided for your records to show that all personnel who will be working with the attachment have read and understand the information in this Operator Manual and have been trained in the operation of the machine the attachment is connected to. The user and the owner should both sign and date the form to indicate acceptance of the risk of using the pallet fork.

**Authorization / Training Sign-Off Form**

<b>Date</b>	<b>User's Signature</b>	<b>Owner's Signature</b>

## 3. Safety Decals and Labels

### 3.1 General Information

The types of safety decals (hazard labels) and instructional labels, along with their locations on the pallet fork are shown in the following illustrations. Good safety practices require that you familiarize yourself with the various safety decals, the type of warning, and the area or particular operation related to that area that requires your SAFETY AWARENESS.



**Think SAFETY!**

**Work SAFELY!**

Pay close attention to the safety decals and instructional labels attached to the machine and pallet fork. The safety decals affixed to the pallet fork are reproduced in this section. If the pallet fork is missing a label or one is unreadable, replace the label before using the pallet fork.

#### SAFETY INSTRUCTIONS



#### *Safety Decals and Instructional Labels*

1. **Keep safety decals or instructional labels clean and legible at all times. Use a clean, damp cloth to clean safety decals.**
2. **Replace any missing or hard-to-read safety decals or instructional labels.**
3. **Use care when washing or cleaning the pallet fork not to remove or damage the decals. When using a pressure washer to clean the pallet fork, avoid spraying too close to decals; high-pressure water can enter through very small scratches or under edges of decals causing them to peel or come off.**
4. **Locations for the decals and replacement part numbers are shown in this section.**
5. **Replacement parts must have replacement decals attached before the pallet fork is used.**
6. **Decals are available from your authorized dealer or from Norden Mfg LLC at no charge.**

### 3.2 Contact Information

For replacement decals, contact:

Norden Mfg LLC  
4210 Kinsman Road NW  
North Bloomfield, OH 44450

Phone: 877-296-5851  
Fax: 440-693-4336  
E-mail: [parts@nordenmfg.com](mailto:parts@nordenmfg.com)

### 3.3 How to Install Replacement Safety Decals

1. Clean and dry the installation area.

**Note:** Do not install the decals if the temperature is below 50°F.

2. Determine the exact position before you remove the backing paper.
3. Remove the backing paper.
4. Align the decal or label over the specified area and carefully press the sign to the part/frame.

**Note:** Small air pockets can be pierced with a pin and smoothed out using the piece of backing paper or plastic card.

### 3.4 Safety Sign Locations

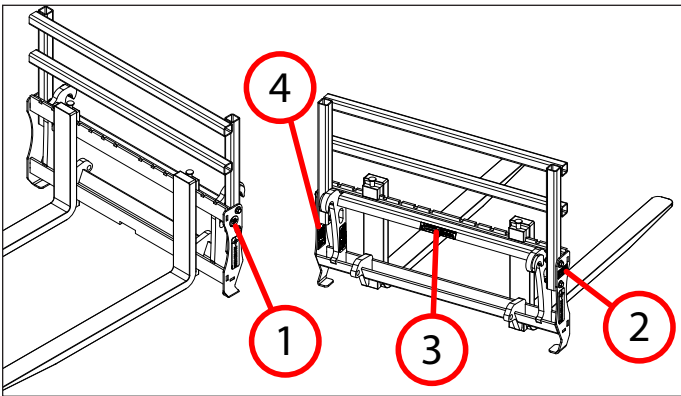

Item	Type	Description	Qty.
1	INFORMATIONAL	Read the Manual	1
2	WARNING	No Riders	1
3	WARNING	Falling Hazard	1
4	INFORMATIONAL	Mfg Placard	1



**NORDEN** MFG  
4210 Kinsman Rd NW  
North Bloomfield, OH 44450  
**(877) 296-5851**  
www.nordenmfg.com  
Made in USA 

MEMBER



**FEMA**  
FARM EQUIPMENT  
MANUFACTURERS  
ASSOCIATION

4. 1027180

INFORMATIONAL — Manufacturer Placard

### 3.5 Safety Decals



1.  
INFORMATIONAL — Read the Manual



2.  
WARNING — No Riders



3.  
WARNING — Falling Hazard

## 4. Nomenclature

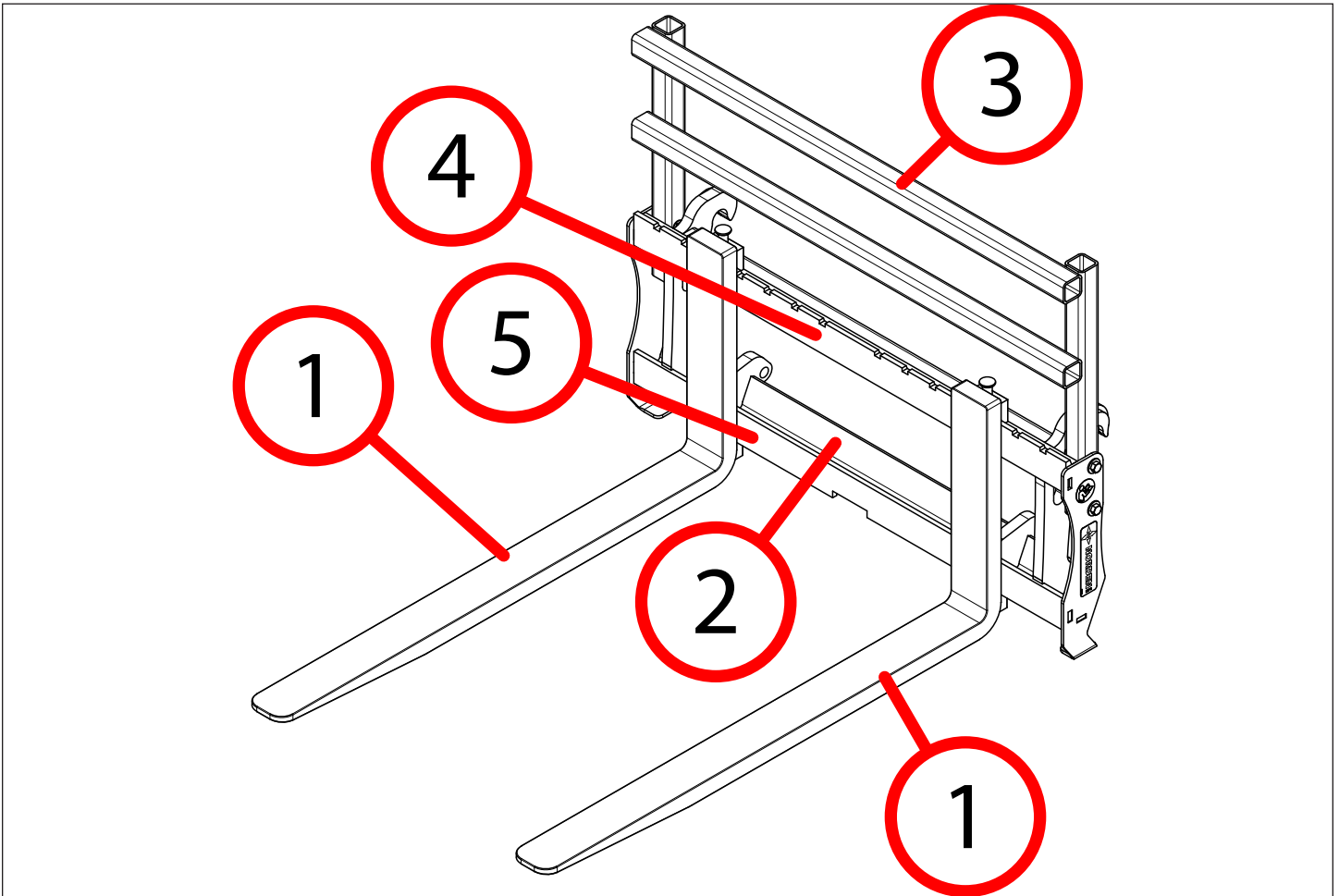

Item	Description
1	Fork Arm
2	Frame (weldment)
3	Brick Guard or Backrest
4	Top Carriage Bar
5	Lower Carriage Bar

## 5. Assembly and Setup

### 5.1 Installing Fork Arms On Pallet Fork Frame

The Pallet Fork does not come assembled from the factory. If needed, carefully follow these instructions to assemble your Pallet Fork.

#### **CAUTION**



Follow these instructions carefully for safe fork arm installation on the pallet fork frame to avoid personal injury or equipment damage.

#### **CAUTION**



Pinching hazard! Keep hands and fingers clear of the area between carriage bars and fork arms.

#### Step 1: Preparation

- Torque nuts and/or bolts on the pallet fork frame, if applicable.
- Locate fork arm locking pin on the backside of the fork arms.
- Locate the slot centered on the bottom edge of the lower fork carriage bar.

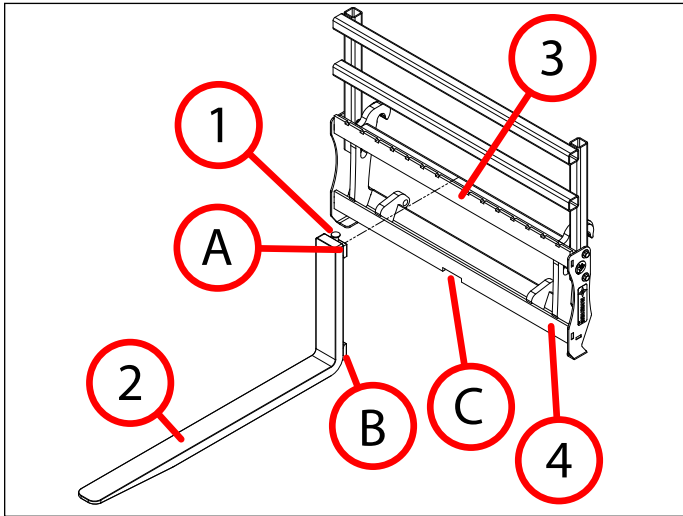

Item	Description
1	Fork Arm Lock Pin
2	Fork Arm
3	Upper Carriage Bar
4	Upper Carriage Bar
A	Upper Retaining Hook
B	Lower Retaining Hook
C	Slot

#### Step 2: Install the first fork arm

1. Raise and lock fork arm locking pin (#1).
2. Center the upper hook of first fork arm (#2) on upper carriage bar (#3).
3. Lower retaining hook (A) onto upper carriage bar (#3), and fit retaining hook (B) through slot (C) in lower carriage bar (#4).
4. Slide first fork arm towards the right, applying pressure near carriage bars (#3 & #4), until locking pin (#1) aligns with a pin notch.
5. Release and seat locking pin handle (#1) in a chosen notch, ensuring full engagement and secure attachment of retaining hooks (A) and (B) behind the carriage bars.

#### Step 3: Install the second fork arm

1. Repeat Steps 1-5 for the second fork arm, sliding it towards the left.

#### **WARNING**

**Prevent Fork Arm Disengagement**  
 If the fork arm locking pin is not fully engaged, the fork arm could become unintentionally disengaged, causing serious injury.

#### **NOTICE**

#### Maintain Balanced Placement

Do not place both fork arms on the same side of the slot opening; keep an equal distance from the frame center.

#### **NOTICE**

#### Confirm Secure Installation

Ensure both fork arms are properly installed and securely locked before using the pallet fork. For light-weight tractors or specific skid steer loaders, consult the Skid Steer or Tractor Operator's Manual to determine if rear ballast is required for heavy loads to maintain steering control.

**Note:** Installation and movement of the fork arms is made much easier if grease is applied to the top of the top carriage bar and to the front face of both carriage bars.

## 6. Usage

### 6.1 User Safety

Refer to “2.4 General Safety” on page 8 for additional safety information.

#### 6.1.1 Machine Operation Recommendations

#### **WARNING**

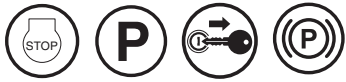

#### **Roll Away Hazard**

Before leaving the operator's seat, make

sure the engine is stopped, the transmission is placed in park, the key is removed, and the parking brake is set.



#### **Rollover Hazard**

The weight of the machine, plus the pallet fork, if it rolls onto a person, could cause serious crushing injury or death.









#### **Entanglement Hazard**

If using a small compact or utility tractor, keep hands and clothing clear of any rotating parts. Stay clear of the pallet fork while it is moving.

#### **SAFETY INSTRUCTIONS**

The following safety instructions are provided to help prevent injury or limit pallet fork damage.

-  *It is the owner's responsibility to make sure any person using a machine with the attachment, especially if it is loaned or rented, has been thoroughly trained on its proper and safe use.*
-  *Be certain only physically-able persons will use the attachment.*
-  *Users who have not read and understood all operating and safety instructions are not qualified to use the attachment.*
-  *If the elderly are assisting with the work, their physical limitations need to be recognized and accommodated.*
-  *Never allow children to use the attachment.*

 *Be especially observant of the operating area and terrain – watch for loose fill, holes, rocks or other hidden hazards. Always inspect the area prior to operation.*

 *Be careful at the edge of ditches or gullies. Be careful when working on inclines.*

 *Do not use excessive speed when moving pallets.*

 *Allow for pallet fork length when making turns.*

#### 6.1.2 Machine Requirements

#### **WARNING**





#### **Machine Operator Manual**

Always refer to the machine's operator manual to ensure compatibility and maximum safety.

The machine must be equipped with a front-end loader with Euro attachment mounting style rated to lift the pallet fork which can weigh up to 430 pounds plus the weight of the pallet and load.

#### **SAFETY INSTRUCTIONS**

 *Do not use an oversized machine; the pallet forks are intended to be used on machines rated up to 120 HP or a 5500 pound operating capacity.*

 *Using the pallet fork with a machine that exceeds the specified requirements may cause machine or attachment damage, be a potential danger to the operator or bystanders, and will void any warranty.*

 *Always review the “controls” section of the machine's Operator Manual to be familiar with the location, settings, and function of the controls. Be familiar with all controls before using this attachment.*

## 6.2 Machine Specifications

This section is provided to give the operator general safety information for the machine. Always follow the OEM instructions given in the operator's manual for the machine.

### **WARNING**



#### **Rollover Hazard**

To avoid serious injury or death from falling, runover, rollover, or crushing, the machine must have an approved Roll-Over Protective Structure (ROPS) or ROPS cab and seat belt.

### **CAUTION**



#### **Tire Failure Hazard**

Inspect the tires of the machine for full operational reliability. Failure of the tires could result in damage to the machine, load or attachment.

1. The machine must be equipped with an approved Roll-Over Protective Structure (ROPS) or ROPS cab and seat belt.
  - a. If equipped with a folding ROPS structure, keep it locked in the UP position.
  - b. Only operate the machine when seated in the operator seat.
  - c. Always fasten seat belt whenever the machine is moving.
2. If working around dry grass or vegetation, to reduce the risk of fire, do not use a machine with an under-frame exhaust.
3. If the machine must travel on a public roadway, follow guidance given in "7. Transporting" on page 20.
4. Maintain all manufacturer's safety shields and guards

## 6.3 Attaching to Machine

### **WARNING**



#### **Pinch Point Hazard**

Use caution when connecting the attachment to the machine. Keep hands and feet from under the attachment and clear of pinch points between frame and machine. Do not allow anyone to stand between the machine and pallet fork during attachment process.

1. Ensure there are no potential unintended collisions between the attachment and the loader before connecting them for the first time.
2. Tilt the tool carrier forward completely to angle the carrier arms downward toward the attachment. Position the tool carrier an inch below the attachment hooks.
3. Drive the machine forwards slowly, centering the carrier arms between the hooks on the attachment.
4. When the tool carrier makes contact with the attachment, raise the loader arms to engage both hooks of the attachment on the tool carrier.
5. Roll the tool carrier back toward the machine.
6. If equipped, the hydraulic or electronic powered locking pins can be engaged. In this case; skip Steps 7, 8, and 9.
7. If your loader requires manual locking, perform a full roll back to automatically lock the attachment onto the tool carrier.
8. If your loader requires a fully manual locking process:

### **WARNING**



#### **Roll Away Hazard**

Before leaving the operator's seat, make sure the engine is stopped, the transmission is placed in park, the key is removed, and the parking brake is set.

- a. Raise the back of the attachment slightly off the ground and angle it back to apply pressure against the stops.
- b. Shut off the machine.
- c. Apply the parking brake.



- d. Manually lock the attachment to the carrier assembly.

**WARNING**



**Injury Hazard**

To avoid serious injury or death caused from falling attachment: lock pins must completely engage attachment eyes.



**Crush Hazard**

Do not stand under raised attachment.

9. If equipped, the attachment’s locking lug will impact/push aside the Click-on system on the tool carrier, automatically locking the attachment in position. The lock lever is released and moves to the “locked attachment” position.
10. Raise the loader arms until the tool carrier is clearly visible from the driver’s cab. Inspect alignment and verify positioning.
11. Pay attention to the tool carrier lock indicators, which may differ depending on the type of tool carrier installed on the loader. Carefully observe how your specific tool carrier indicates a locked attachment.
12. Before starting work with the loader/attachment, read “6.4 Pre-Operation Checklist” on page 17 to ensure the attachment is correctly locked onto the loader’s tool carrier:
  - Visually check that the locking lever indicates a locked attachment.
  - Visually check that the tool carrier locking pins are in the locked position.
13. Verify that the attachment is locked in place on the tool carrier by pressing the front of the attachment against the ground.
14. Before using the attachment, the operator must operate it through its full range of motion and confirm that the attachment is secure and safe.

**6.4 Pre-Operation Checklist**

Before each use of the attachment, the following areas should be checked.

Checklist Before Each Use	
<input checked="" type="checkbox"/>	Task
	Make sure the pallet fork is positively attached to the machine. Refer to “6.3 Attaching to Machine” on page 16.
	If the machine uses tires, make sure they are inflated properly and the lug nuts are tight.
	Inspect the tires of the machine for full operational reliability. Failure of the tires could result in damage to the machine, load or attachment.
	Visually inspect the attachment for any loose bolts, worn parts, or cracked welds. Make necessary repairs before using the attachment.
	Make sure the pallet fork frame and fork arms are not bent or cracked.
	Make sure the operating area is clear, especially of children and animals.

**6.5 Usage**

Before using the attachment, the operator must have a complete understanding of how to operate the machine including all controls, and how to use the attachment.

The operator should read and understand the Safety and Operation sections of the machine Operator’s Manual. It is important to note that these manuals must be read and explained to any operator who cannot read. It is crucial to never allow anyone to operate the machine or use the attachment without complete operating instructions.

To ensure safety to the operator, bystanders, and equipment, the operator must become familiar with the surrounding work area and any obstacles and hazards contained within before starting any operation. Special attention should be paid to foreign debris, rough terrain, steep slopes, bystanders, or animals in the area.

If the operator is not already familiar with the process, it is recommended to practice lifting, lowering, maneuvering, and placing a pallet on a level site until the confidence and skill needed to safely move pallets is achieved. It is important to follow the safety operating procedures that are spelled out in this Operator’s Manual.

## WARNING



### Crush Hazard

When handling pallets, improper use of the machine can result in serious injury or death to the machine operator. This could be caused by the contents of the pallet falling or rolling backwards into the operator's station. Therefore, it is important to handle pallets safely.

## CAUTION



### Tip Over Hazard

It is important not to exceed 5,500 lbs. or the lift capacity of the machine. The operator should not lift the pallet too high, creating an unstable and unsafe situation. The operator should also avoid tilting the pallet too far forward, setting up a situation that could cause the pallet to prematurely slide off the fork arms.

The operator must travel at a safe speed for ground conditions. Travel slowly over rough ground or when making turns. Working on or around slippery or sloped areas could cause the operator to lose control of the machine.

The operator must not allow bystanders, pets, or livestock to approach the danger zone of the working area.

The operator must not leave the machine with the attachment raised off the ground.

### 6.5.1 Picking Up a Pallet

1. Verify that the load does not exceed the smaller of the two lift capacities:
  - Rated lift capacity of the pallet forks.
  - 83% of the rated lift capacity of the machine.

**Note:** Using 83% of the rated lift capacity accounts for increased loader stresses caused by the extended fork arms and ensures proper tire rating.

## NOTICE

*Care must be taken to ensure there is enough overhead clearance and no potential hazards or obstructions that could interfere with the lifting and placing of the pallets.*

2. Position the fork arms centrally under the pallet to ensure even weight distribution. Always center the pallet horizontally on the fork arms to optimize stability while transporting.

## SAFETY INSTRUCTIONS

**Transport pallets at a height that maintains a clear line of sight and keep the pallet low to the ground when possible to enhance stability.**

3. Check for any overhead obstructions.
4. Bring the machine to a complete stop before adjusting the forks to the correct height.
5. Drive forward as far as possible into the pallet.
6. Lift the load just off the location it was and tilt it back slightly.
7. Confirm that the pallet is balanced and securely positioned.

## NOTICE

**Potential Damage.** Partial engagement of the fork arms can damage the fork arms, as it locates the weight of the pallet on the outer end of the fork arms.

8. Verify that no animals or bystanders are behind you and that it is safe to reverse.
9. Slowly reverse to clear storage racks or other obstacles.
10. Position the pallet fork at a safe traveling height before moving. It is recommended to keep it two to four inches above the ground.

**Note:** To minimize jerking, stop and start the loader gradually when lowering or lifting loads.

## NOTICE

**No Chains.** Do not attach chains intended for lifting or securing loads to the pallet fork frame, as it may cause damage.

## SAFETY INSTRUCTIONS

**Always ensure the tractor is properly ballasted before attempting to lift any load with the attachment.**

### 6.5.2 Moving the Pallet

1. Always yield to pedestrians.
2. Transport pallets fully against the pallet fork frame.
3. Tilt the pallet back slightly.
4. Keep the forks low, preferably two to four inches above the ground.

- Continuously scan all sides for bystanders or other traffic.

### SAFETY INSTRUCTIONS

***Make sure that the work area is clear of children, animals, and other obstacles before using the attachment. This is particularly important in areas with higher noise levels or quiet cabs, as you may not hear people shouting.***

- If the pallet obstructs your view, travel in reverse.
- Maintain a safe and controlled speed, reduce speed when turning, and avoid sudden braking.
- Provide adequate clearance while turning to avoid contact between the pallet forks, pallet, and obstacles such as storage racks, buildings, trees, or fences.
- When traveling over ramps or inclines, keep the pallet on the “uphill” side of the machine.
- Whenever possible, travel straight on grades, ramps, and inclines, avoiding turns.
- Only raise or lower the pallet when the machine is stopped, not during travel.
- Reduce speed when traveling over rough or hilly terrain.
- Do not transport pallets on public roadways.
- If using public roadways, ensure safe transportation to allow faster vehicles to pass.
- Plan your route to avoid heavy traffic.
- Keep equipment away from electrical power lines and place orange warning signs under overhead electrical power lines to indicate the danger.

#### 6.5.3 Placing the Pallet

- Bring the machine to a stop in front of the desired location for pallet placement.
- Gradually raise the pallet to the required height.
- Move the machine forward slowly with the pallet raised until it is positioned squarely and directly above the final destination.
- Level the pallet for proper placement.
- Slowly lower the pallet onto its final resting location.
- Before reversing, check all sides for bystanders or other traffic.

- After the pallet has settled, slowly back up.
- Ensure that the forks clear the pallet before making any turns or adjusting the fork height.
- Lower the forks before resuming movement.

#### 6.6 Detaching from Machine

### CAUTION



#### Pinch / Crush Hazard

**Use caution when disconnecting the attachment from the machine.**

**Keep hands and feet from under the attachment and clear of pinch points. Do not allow anyone to stand near the machine or attachment when disconnecting.**

- Move the machine onto a flat, level, solid surface. Lower the attachment slightly above the surface with the hitch angled, front of the attachment slightly higher than the rear.
- If your machine is equipped with hydraulically operated locking pins, retract the coupler lock at this time. In this case; lower the attachment to the ground and skip Steps 3, 4, and 5.
- Shut down the machine and set the parking brake properly without lowering the attachment.

### WARNING



#### Unintended Movement

**Before leaving the operator's seat, make sure the engine is stopped, the transmission is placed in park, the key is removed, and the parking brake is set.**

- Move the locking lever to disengage the locking pins.
- Start the engine and lower the attachment to the ground.
- Tilt the tool carrier forward to allow the tool carrier to clear the hooks on the attachment.
- Make sure the area is clear of bystanders and animals, then slowly back the machine away from the attachment, ensuring that the tool carrier does not interfere with the attachment.

## 7. Transporting

### 7.1 Highway and Transport Safety

This section is provided to give the operator general safety information for the machine. Always follow the OEM instructions given in the operator's manual for the machine.

Refer to "2.4 General Safety" on page 8 for additional safety information.

#### SAFETY INSTRUCTIONS

**SI** *Make sure the machine used is in good operating condition according to the OEM user's manual.*

**SI**  *When traveling on the highway, make sure the machine has a clearly visible "Slow Moving Vehicle" placard.*

**SI** *Use approved accessory lighting, flags, or other necessary warning devices to protect operators of other vehicles on the highway during daylight and nighttime transport. Various safety lights and devices are available from the OEM of your machine.*

**SI** *Do not allow anyone to ride on the machine or the pallet fork.*

**SI** *Always drive at a safe speed relative to conditions, and ensure that the speed is low enough for an emergency stop. Keep speed to a minimum.*

**SI** *Reduce speed prior to turns to avoid the risk of overturning.*

**SI** *Always keep the machine in gear to provide engine braking when going downhill. Do not coast.*

**SI** *Be a safe and courteous driver. Always yield to oncoming traffic in all situations, including narrow bridges, intersections, etc. Plan your route to avoid heavy traffic.*

**SI** *Travel on roadways in such a way that faster moving vehicles can pass safely.*

**SI** *Always travel with the attachment in a position to provide maximum visibility at all times. Make allowances for increased length and weight of the pallet fork when making turns, stopping, etc.*

### 7.2 Pre-transport Checklist

1. Before transporting, make sure the maintenance on the machine is current.
2. If applicable, check the tire pressures on the machine, and correct if necessary.
3. Make sure the attachment is securely attached to the machine. Always inspect the pallet fork and frame for damage or abnormal wear before attaching.
4. Prior to traveling on a public road, have an observer confirm all running lights, brake lights, turn signals, and hazard lights are working on the machine.
5. Verify the brakes are operating correctly.

## 8. Storage

---

Refer to “2.4 General Safety” on page 8 for additional safety information.

### CAUTION



#### **Stay Clear**

**Do not permit anyone, especially children to play on or around the stored pallet fork. Store the pallet fork in an area away from human activity.**

### SAFETY INSTRUCTIONS

**SI** *Do not store the pallet fork where it will be exposed to livestock. Damage and livestock injury could result.*

### 8.1 Placing in Storage

1. Thoroughly wash the attachment with a pressure washer or water hose to remove all loose dirt, mud, or debris.
2. Select an area that is dry, level, and free of debris (inside a building is ideal). Move the pallet fork to its storage area.
3. Follow instructions in “6.6 Detaching from Machine” on page 19.

### 8.2 Removing from Storage

1. Attach the pallet fork to the machine following the procedure in section “6.3 Attaching to Machine” on page 16.
2. Before placing the pallet fork back into service, replace any worn or defective parts and perform the “6.4 Pre-Operation Checklist” on page 17.



## 9. Maintenance

Good maintenance is the owner's and operator's responsibility. Poor maintenance shortens pallet fork life and is an invitation for problems.

Norden Mfg LLC will not claim responsibility for use of unapproved parts and/or accessories and other damages as a result of their use.

If the attachment has been altered in any way from its original design, Norden Mfg LLC will not accept any liability for injury or warranty.

### 9.1 Maintenance Safety

#### **WARNING**



#### **Unintended Movement**

If the attachment is attached to a machine, make sure the engine is stopped, the transmission is placed in park, the key is removed, and the parking brake is set.



#### **Personal Protection Equipment**

Wear personal protection equipment (PPE), which may include safety glasses, safety shoes, gloves, etc. appropriate for the work site and working conditions.



#### **No Unauthorized Modifications**

Do not modify the attachment or safety devices. Unauthorized modifications may impair the function of the attachment, or create safety hazards, and will void the warranty. If the pallet fork has been altered in any way from the original design, Norden Mfg LLC does not accept any liability for injury or warranty.



#### **Damaged Parts Hazard**

Do not use the attachment if any parts are damaged. If the pallet fork is believed to have a defect which could cause it to work improperly, immediately stop using it and remedy the problem before continuing.



#### **Unintended Consequences**

Do not weld on the pallet fork frame or fork arm. Doing so will cause a stress point which will result in failure of the part.

#### **WARNING**



#### **Crush Hazard**

Always set the pallet fork on blocks or on the ground when performing maintenance.



#### **Good Working Condition**

Keep all parts in good working condition and properly installed. Fix damage immediately. Replace worn or broken parts.



#### **OEM Replacement Parts**

If replacement parts are necessary, genuine factory replacement parts must be used to restore the attachment to its original specifications. Unapproved parts could create a safety hazard. Norden Mfg LLC will not accept responsibility for damages as a result of the use of unapproved parts.

### 9.2 Practice Safe Service Procedures

#### **CAUTION**



Understand service procedures before doing any work. Keep the work area clean and dry.



Keep all parts in good working condition and properly installed. Replace worn or broken parts immediately.



A first aid kit should be readily accessible while performing maintenance on the pallet fork.



Do not leave tools lying around the work area. Follow good shop practices. Keep service area clean and dry. Be sure electrical outlets and tools are properly grounded. Use adequate light. After servicing, be sure all tools, parts and service equipment are removed.



Use the correct tools, jacks, hoists, or other components that have the capacity for the job.

### 9.3 Bolt Torque Requirements

#### **WARNING**



#### **Equipment Failure**



The proper torque value for bolts and cap screws is identified by their head markings. Replacing higher “grade” bolts (Grade 5) with lower grade bolts will lead to equipment failure and could result in injury or death. Always use replacement bolts with the same grade markings as the removed bolt.

It is extremely important to apply and maintain proper torque on all bolts. Use a torque wrench to assure the proper amount of torque is being applied to the fastener.

Start all bolts or nuts by hand to prevent cross-threading.

Torque figures indicated in the chart are used for non-greased or non-oiled threads unless otherwise specified. Therefore, do not grease or oil bolts or cap screws unless otherwise specified in this manual. When using locking elements, increase torque values by 5%.

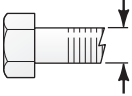
The chart gives correct torque values for various bolts and cap screws. Tighten all bolts to the torque specified in the chart unless otherwise noted. Check tightness of bolts periodically, using the bolt torque chart as a guide. Always replace hardware with the same grade bolt.

Bolt Diameter 	English Bolt Torque Specifications			
	Grade 5  3 Radial Lines		Grade 8  6 Radial Lines	
	ft. lbs.	N·m	ft. lbs.	N·m
1/4"	9	12	12	17
5/16"	19	25	27	36
3/8"	33	45	45	63
7/16"	53	72	75	100
1/2"	80	110	115	155
9/16"	115	155	165	220
5/8"	158	215	220	305
3/4"	290	390	398	540
7/8"	420	570	650	880
1"	630	850	970	1320

### 9.4 Welding Repairs



Before performing any type of welding repair to the attachment frame, contact Norden Mfg LLC for approval. Repair welding must be done with care and with procedures that may be beyond the capabilities of the ordinary welder.

#### **WARNING**



#### **Personal Injury Hazard**

Repairs or modifications to the attachment could result in serious injury or death to the operator or bystander should these repairs fail. Do not weld or repair fork arm. If damaged, replace fork arms with new OEM parts.

#### **NOTICE**

Anyone performing a welding repair should be certified in accordance to the American Welding Society (AWS) standards.

## 9.5 Service Record

The service period recommended is based on normal operating conditions. Severe or unusual conditions may require more frequent service.

Copy this page to continue record.

Hours and Serviced By													
<b>Maintenance</b>													
<b>Every 8 Hours of Use</b>													
Visually inspect the fork arms for hairline cracks.													
<b>Annually</b>													
Make sure all fasteners are tightened to proper torque. Refer to "9.3 Bolt Torque Requirements" on page 23.													
Inspect and replace damaged safety decals or instructional labels.													
Wash the pallet fork.													
Inspect attachment frame for cracking or damage.													



## 10. Parts Section

---

### 10.1 Ordering Parts

Norden Mfg LLC manufactures a quality product that requires very little maintenance or repair. However, should a part break or become damaged, our knowledgeable staff can make sure you receive the part(s) to put your pallet fork back into operation.

### 10.2 Contact Information

For replacement decals, questions, or to order parts, contact:

Norden Mfg LLC  
4210 Kinsman Road NW  
North Bloomfield, OH 44450

Phone: 877-296-5851

Fax: 440-693-4336

E-mail: [parts@nordenmfg.com](mailto:parts@nordenmfg.com)

### 10.3 Safety Decals and Instructional Labels

Safety decals and instructional labels provide a vital role in helping to reduce injuries and/or possibly even death. To ensure the greatest level of safety, all decals must be in place and legible or all warranties are void. Remember, it is the user's responsibility to maintain these decals and labels.



**To prevent serious injury or death which could result from not following posted safety instructions, make sure all decals are attached to any**

**replacement part.**

## 10.4 EPF 5500 Parts Detail

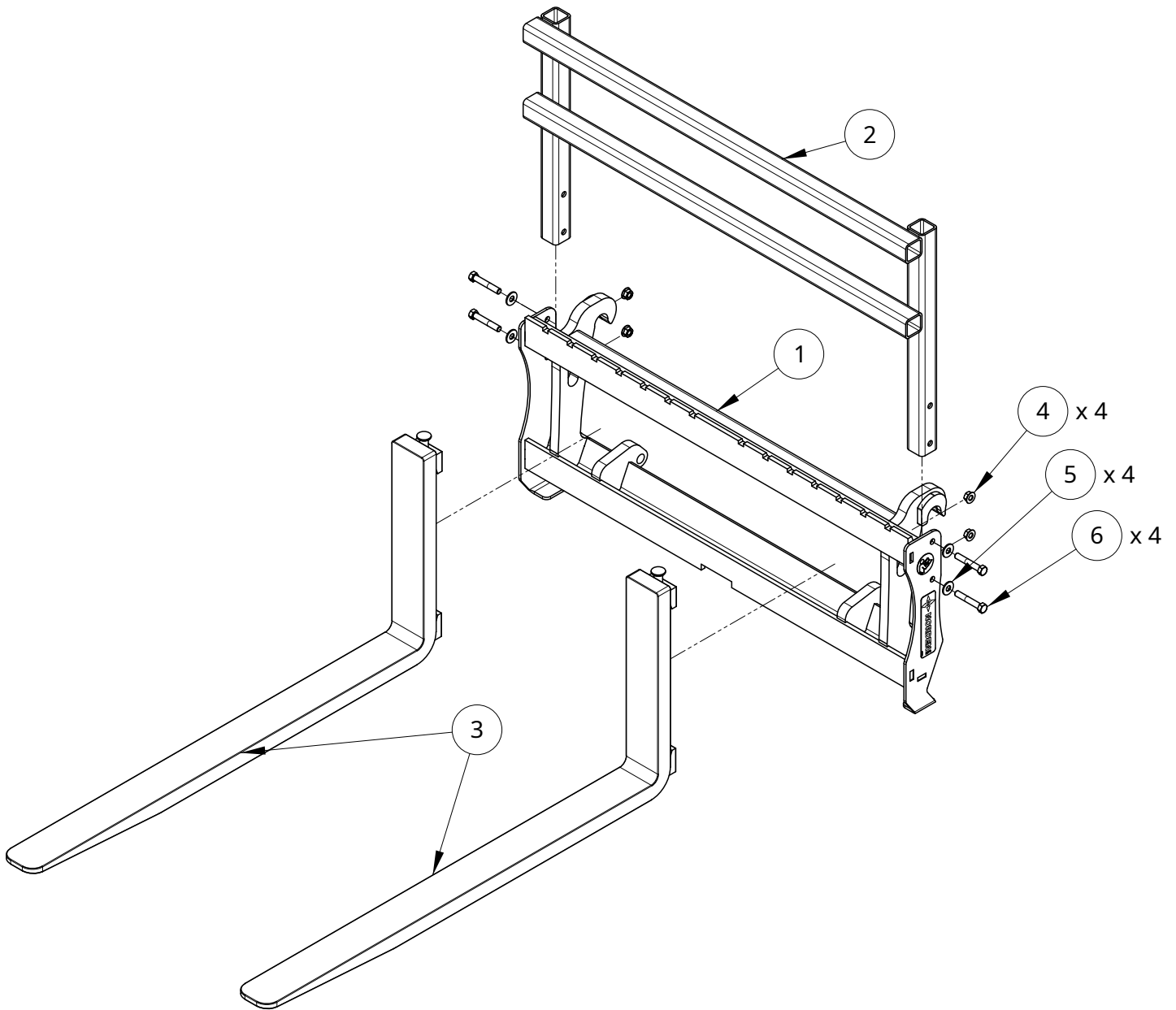

Item	Quantity	Part number	Name	Finish
1	1		Euro Pallet Fork frame weldment	Black
2	1	1028740	Euro Pallet Fork Backrest weldment	Black
3	2	1027390	Pallet Fork, 1.56x4x48, 5,500 lb cap per pair	Black
4	4	1006210	Hex flange nut 1/2-13	Zinc
5	4	1006170	Type B regular flat washer 1/2	Zinc
6	4	1006250	Hex bolt 1/2-13 x 3 x 1.25	Zinc

**No content for this page.**

This is an example of a positive negative.

*Fun Fact: Books like this are sized in multiples of four pages. This is because a single piece of 11" x 17" paper yields four sides of 8 1/2" x 11" paper.*



# **NORDEN** MFG

Norden Mfg LLC  
4210 Kinsman Rd NW  
North Bloomfield, OH 44450

**(877) 296-5851**  
[www.nordenmfg.com](http://www.nordenmfg.com)  
[support@nordenmfg.com](mailto:support@nordenmfg.com)